

USB ⇔ RS-485 Converter



Part Number: USB-232-1+CVT-485-1



■ INTRODUCTION

This USB ⇔ RS485 converter is a port-powered bi-directional USB to RS485 converter, which can be used to convert any standard full-duplex USB port into a two-wire half-duplex RS485 port and vice versa. The unit can be used to communicate with one loop of up to 128 units of RS485 devices. The unit is powered from the USB port and it supports data auto-sensing & self-adjusting, no baud rate setting is required. And with the data direction auto-turnaround technology, no external power or flow control is required for RS485 communications.

The unit uses the latest FTDI chipset and is fully compatible with Windows 7/Vista/XP/Server2008/2003/2000/98 (32-bit), Windows 7/Vista/XP/Server2008/2003 (64-bit), Win CE, Mac, and Linux. Note: the latest drivers (chipset FT232B) are available at <http://www.ftdichip.com/Drivers/VCP.htm>.

■ FEATURES

- Adds one RS-485 port to your USB port.
- Communicate with one loop of up to 128 units of RS485 devices.
- Built-in 120Ω end-of-line terminator for easy installation.
- Data direction auto-turnaround, no flow control is required.
- Supports 300 to 115,200 baud (auto-sensing and self-adjusting).
- Supports Windows 7/Vista/XP/Server2008/Server2003/2000/98 (32-bit), Windows 7/Vista/XP/Server2008/Server2003 (64-bit), Win CE, Mac, and Linux.
- Supports remote wakeup and power management.
- Plug and play (hot-pluggable, data format auto-sensing and self-adjusting).
- Port-powered, no external power required.
- No IRQs required, no IRQ conflicts.
- CE certified.
- 5-year manufacturer's warranty.

■ SPECIFICATIONS

Compatibility:	USB 2.0 (backward compatible) and EIA/TIA RS-485 standards
Power Source:	From USB port
Current Consumption:	Less than 100mA
Baud Rates:	300 to 115,200bps (auto-sensing and self-adjusting)
Distance:	USB side: 10ft (3m); RS-485 side: Depending on the power from USB port, will transmit up to 4000ft (1.2km) at 19,200bps
Connectors:	USB side: Type A female; RS-485 side: DB-9 male; Termination board: DB-9 female and a 4-way terminal block
Maximum Number of Drops:	128
End-of-line Terminator:	120Ω (Built-in)
Dimensions (HxWxD):	0.63 x 1.3 x 5.5 in (16 x 32 x 140 mm) (excluding cable)
Cable Length:	3.3 ft (1 m)
Weight:	3.5 oz (100 g)
Operating Temperature:	32°F to 95°F (0°C to 35°C)
Operating Humidity:	Up to 90% RH (no condensation)

■ PIN ASSIGNMENT

RS-485 (DB-9 Male Connector / Termination Board):

DB-9 Pin:	1	3	5	9	6,7
Terminal Block:	A+	B-	GND	+5V	Jumper (120)
Function:	RS485+	RS485-	GND	+5V measurement	Terminate/remove Jumper 120 to turn ON/OFF the 120Ω end-of-line terminator

9	+	5V
5		GND
3	-	B-
1	+	A+
6,7		120

- The numbers on the left indicate the pin assignment of DB-9 male connector (RS-485 side).
- DO NOT connect external power to the +5V pin, it is for measurement only. The unit will function correctly only when the voltage on +5V pin is around +5V (when USB port is connected).
- The unit comes with a built-in 120Ω end-of-line terminator; use it (Jumper 120 ON) only when the distance is over 660ft (200m).

■ CONNECTIONS

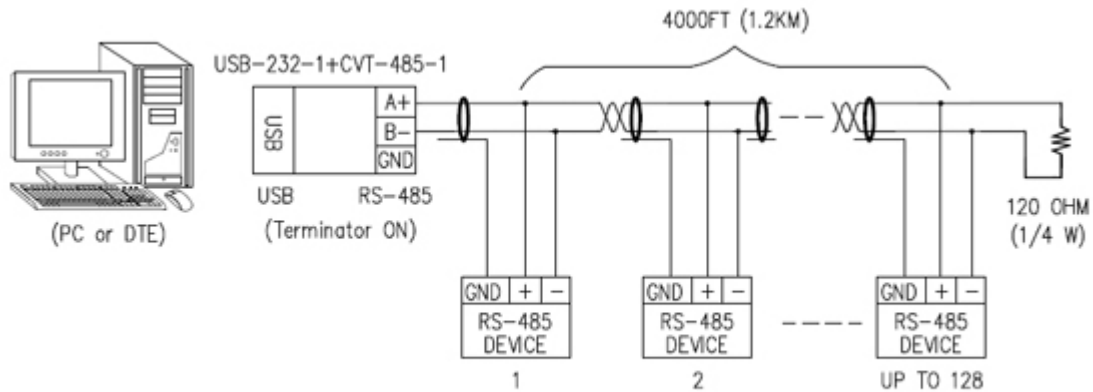

FIGURE 1: MASTER-SLAVE MULTI-DROP CONNECTIONS (RS-485)

■ INSTALLATION NOTES

- The 120Ω end-of-line terminator adds heavy DC loading to a system; connect it only when the RS-485's distance is over 660ft (200m).

■ TROUBLESHOOTING

- Make sure that the USB-RS485 converter is connected to your USB port, and the driver is installed correctly (as shown below); otherwise, please reinstall the driver (refer to <http://www.commfront.com/USB-Driver-Installation-FTDI.htm> for details).

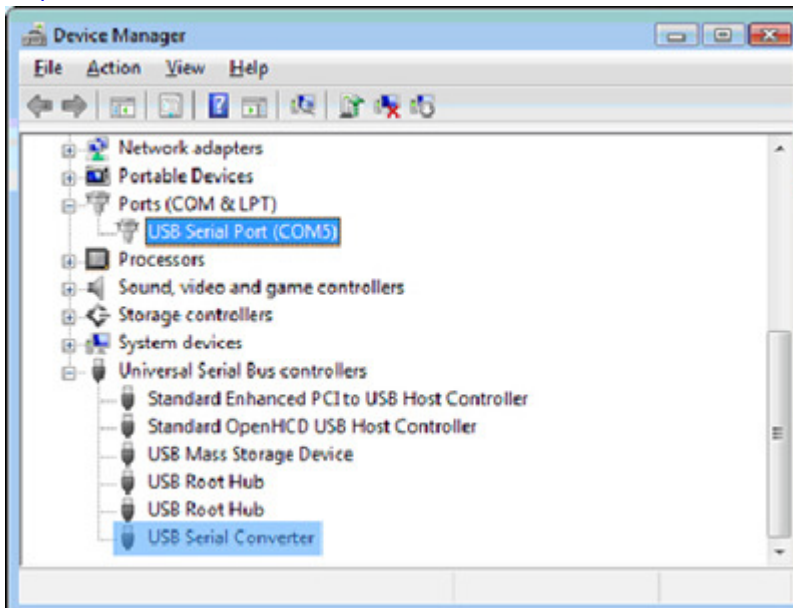

- Perform a loopback test by using CommFront's 232Analyzer software: Connect two numbers of USB-RS485 converters (A+ to A+, B- to B-) to your USB ports and run two instances of the 232Analyzer software, then send commands from one COM port, you should receive an echo of the commands sent on the other COM port. By performing a simple loopback test like this, you can test both the transmitter and receiver of the converter. This is very helpful when you are in doubt about the performance of your converter.