

USB ⇔ RS-422/RS-485 Converter



Part Number: **USB-232-1+CVT-485_422-1**



■ INTRODUCTION

This USB ⇔ RS422/RS485 converter is a port-powered bi-directional USB to RS422 or RS485 converter, which can be used to convert any standard full-duplex USB port into a four-wire RS422/RS485 port or a two-wire half-duplex RS485 port and vice versa. The unit can be used to communicate with one loop of up to 128 units of RS422/RS485 devices. The unit is powered from the USB port and it supports data auto-sensing & self-adjusting, no baud rate setting is required. And with the data direction auto-turnaround technology, no external power or flow control is required. The unit uses the latest FTDI chipset and is fully compatible with Windows 7/Vista/XP/Server2008 /2003/2000/98 (32-bit), Windows 7/Vista/XP/Server2008/2003 (64-bit), Win CE, Mac, and Linux. Note: the latest drivers (chipset FT232B) are available at <http://www.ftdichip.com/drivers/vcp.htm>.

■ FEATURES

- Adds one RS-422 or RS-485 port to your USB port.
- Communicate with one loop of up to 128 units of RS422/RS485 devices.
- Built-in 120Ω end-of-line terminator for reliability and easy installation.
- Data direction auto-turnaround, no flow control is required.
- Supports 300 to 115,200 baud (auto-sensing and self-adjusting).
- Supports Windows 7/Vista/XP/Server2008/Server2003/2000/98 (32-bit), Windows 7/Vista/XP/Server2008/Server2003 (64-bit), Win CE, Mac, and Linux.
- Supports remote wakeup and power management.
- Plug and play (hot-pluggable, data format auto-sensing and self-adjusting).
- Port-powered, no external power required.
- No IRQs required, no IRQ conflicts.
- Surface Mount Technology manufactured to RoHS and ISO-9001 standards.
- Safety: Strictly certified by SGS/TUV (Cert no. SGS - EM2008/20060C; EM/2008/20061C; TUV - SG-CE-090012).
- 5-year manufacturer's warranty.

■ SPECIFICATIONS

Compatibility:	USB 2.0 (backward compatible), EIA/TIA RS422/RS485 standards
Power Source:	From USB port
Current Consumption:	Less than 100mA
Baud Rates:	300 to 115,200bps (auto-sensing and self-adjusting)
Distance:	USB side: 10ft (3m); RS-485/422 side: Depending on the power from USB port, will transmit up to 4000ft (1.2km) at 19,200bps
Connectors:	USB side: Type A female; RS-422/485 side: DB-9 male; Termination board: DB-9 female and a 6-way terminal block
Maximum Number of Drops:	128
End-of-line Terminator:	120Ω (Built-in)
Dimensions (HxWxD):	0.63 x 1.3 x 5.5 in (16 x 32 x 140 mm) (excluding cable)
Cable Length:	3.3 ft (1 m)
Weight:	4.3 oz (123 g)
Operating Temperature:	32°F to 95°F (0°C to 35°C)
Operating Humidity:	Up to 90% RH (no condensation)

■ PIN ASSIGNMENT

RS-485/422 side (DB-9 Male Connector / Termination Board):

DB-9 Pin:	1	2	3	4	5	6	7	8	4
Jumper:	J2 (default: ON)		J3 (default: ON)			J1 (default: ON)		J4 (default: ON)	
RS-485:	A+ (J2 ON) (J2 OFF)		B- (J3 ON) (J3 OFF)		GND	(J1 ON)			

	TX+	RX+	TX-	RX-		
--	-----	-----	-----	-----	--	--

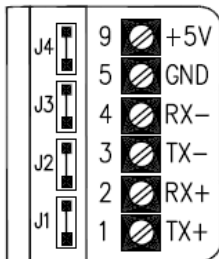

- The numbers on the left indicate the pin assignment of DB-9 male connector (RS-485/422 side).
- The +5V pin is for measurement only, no external power is necessary.
- The unit comes with a built-in 120Ω end-of-line terminator; connect it (Jumper J4 ON) when the data rate is over 19.2kbps or the RS485/RS422's distance exceeds 660ft (200m).

■ CONNECTIONS

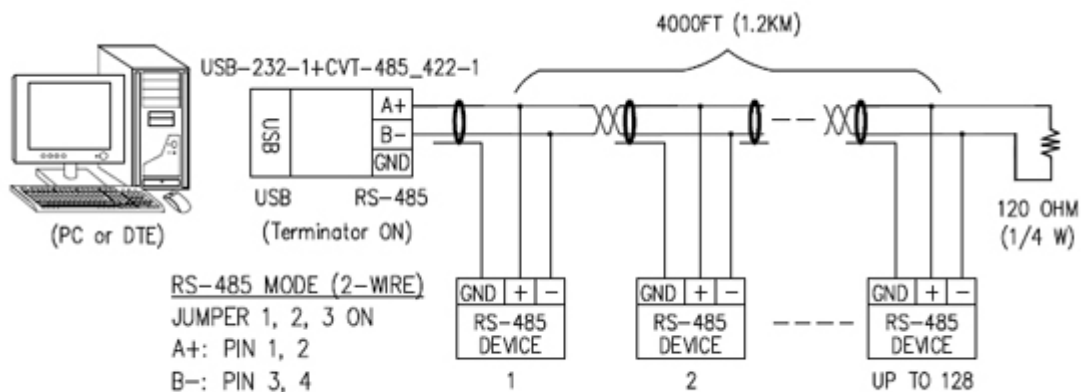

FIGURE 1: MASTER-SLAVE MULTI-DROP CONNECTIONS (RS-485)

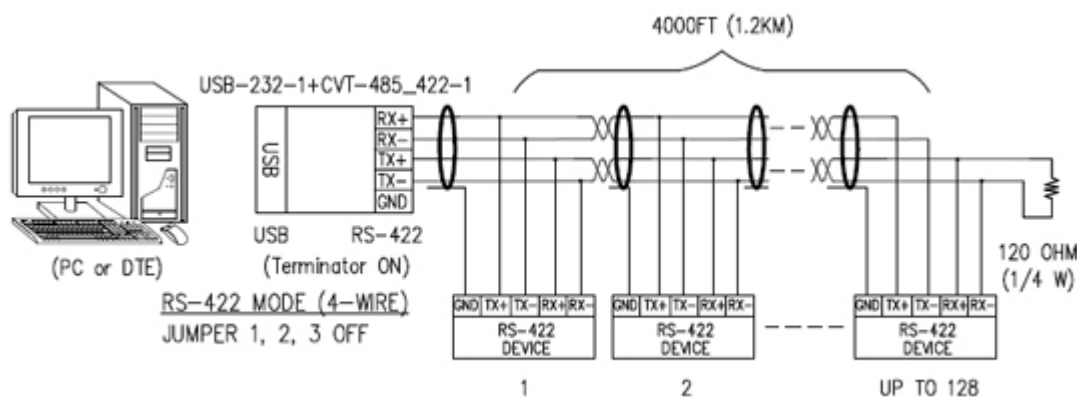

FIGURE 2: MASTER-SLAVE MULTI-DROP CONNECTIONS (RS-422)

■ INSTALLATION NOTES

- The 120Ω end-of-line terminator adds heavy DC loading to a system; connect it only when the data rate is over 19.2kbps or the RS-422/485's distance exceeds 660ft (200m).

■ TROUBLESHOOTING

- Make sure that the USB-RS422/485 converter is connected to your USB port, and the driver is installed correctly; otherwise, please reinstall the driver (refer to <http://www.commfront.com/usb-driver-installation-ftdi.htm> for details).
- Perform a loopback test by using CommFront's 232Analyzer software: Connect a USB-RS422/485 converter to your USB port, remove jumper 1 and terminate Jumper 2 and 3 on the termination board, then send commands from the 232Analyzer software. You should receive an echo of the commands sent. By performing a simple loopback test like this, you can test both the transmitter and receiver of the converter. This is very helpful when you are in doubt about the performance of your converter.